

Verticle & Coin Chute

Changing the Price of the Verticle & Coin Chute

<u>NUMBER</u>	<u>DESCRIPTION</u>	<u>NO. REQUIRED</u>	<u>PART NUMBER</u>	<u>TOOLS REQUIRED</u>
1	SLIDE RETURN SPRING	1	00-8148	5/16 SOCKET WRENCH
2	BUFFER	1	20-2034	PHILLIPS HEAD SCREWDRIVER
3	BLOCKOUT KEY	**	20-5002	
4	DECAL, CASTING	1	00-9905-*	
5	DECAL, SLIDE	1	00-9104*	

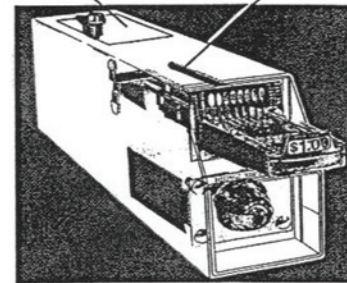
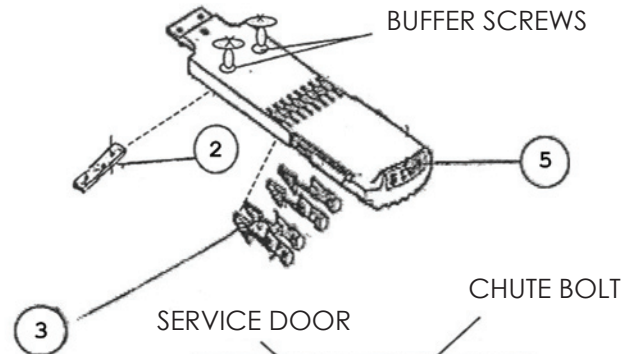
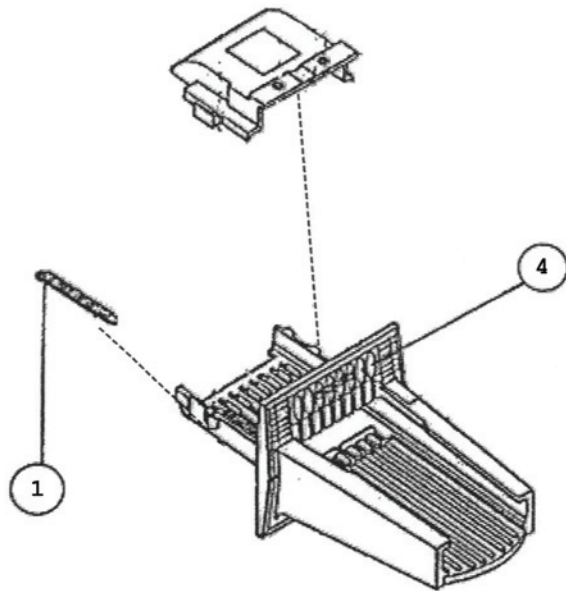

METER CASE

1. Disconnect power to the machine.
2. Open service door.
3. Using a 5/16 socket wrench, loosen and remove the chute bolt.
4. Lifting up and out the coin chute with extension attached, from the meter case.
5. Remove slide return spring (#1).
6. Place coin(s) in coin slot(s) and push forward all the way. **DO NOT PULL SLIDE BACK TO ORIGINAL POSITION UNTIL BUFFER IS REASSEMBLED OR SLIDE WILL JAM.**
7. Remove buffer screws using a Phillips screwdriver. **BE CAREFUL NOT TO STRIP SCREWS.**
8. Turn coin chute upside down and remove buffer (#2).
9. Install/remove required number of blockout keys (#3). Remove keys to increase or add keys to lower the vend.
10. Reassemble buffer.
11. Pull slide back to original position and reassemble slide return spring.
12. Install appropriate price decals (#4 & #5).
13. Once the price is changed re-install the coin chute into the meter case and secure in place and tighten with chute bolt with the socket wrench using Step 3.

GREENWALD INDUSTRIES

212 Middlesex Avenue | Chester, CT 06412 USA | Tel: (860) 526-0800 | Fax: (860) 526-4205

Toll-Free Tel: 1-800-221-0982 | Toll-Free Fax: 1-800-445-1340

www.greenwaldindustries.com

United States & Canada Customer Service & Technical Assistance:
Monday–Friday, 8am to 5pm EST.

Contents, specifications and availability are subject to revisions serving the technical improvement.
Not responsible for any typographical errors.

